

Dual Rail Power Supply

Output is 1mV per *F rise per minute

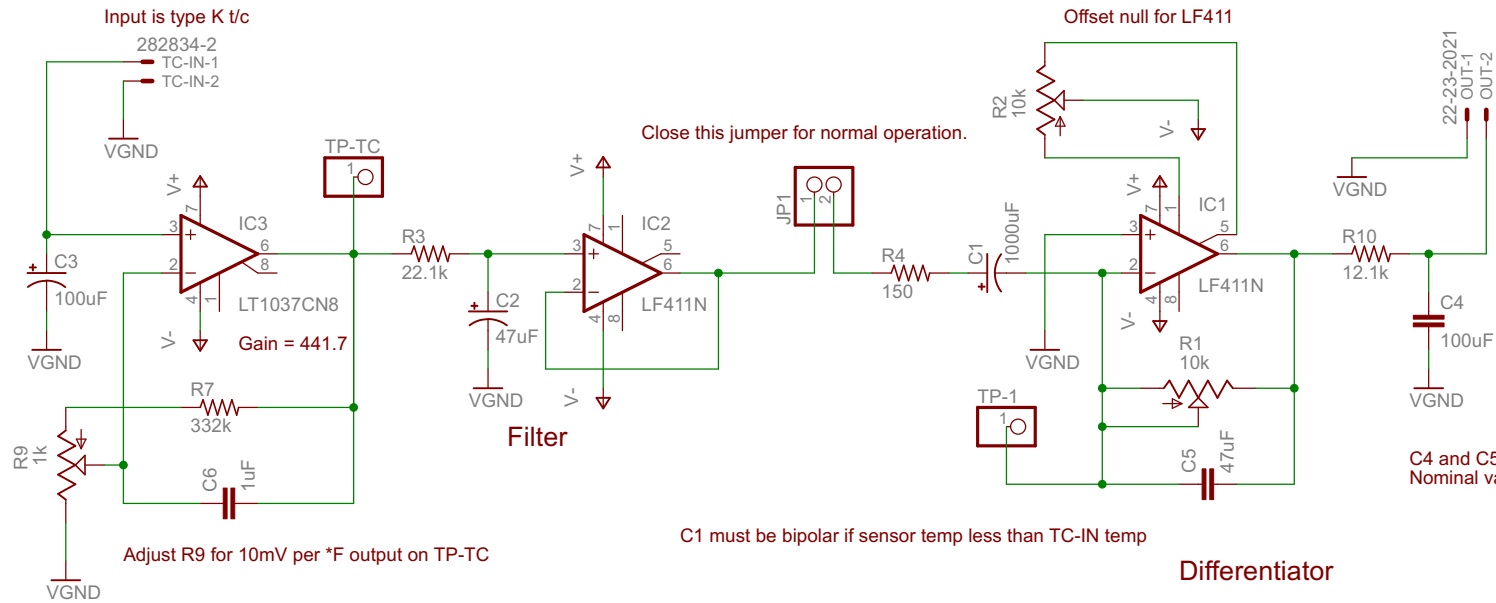

Thermocouple amp

Filter

Differentiator

Adjust R9 for 10mV per *F output on TP-TC

Close this jumper for normal operation.

C1 must be bipolar if sensor temp less than TC-IN temp

C4 and C5 are bipolar
Nominal value for R1 is 6k

Rise-O-Meter V3

TITLE: risemeter03

Document Number:

REV:

Copyright (C) 2010 MLG Properties, LLC

Date: 2/8/2010 1:41:57 PM

Sheet: 1/1